

WEATHER FAX (Weather Facsimile Receiver)

NFX-3000

NSR's new generation of WEATHER FAX:

- SDR (software defined radio) technology adopted
- High receiving sensitivity with noise rejection
- Large 10 inch color LCD, touch screen operation
- Android O/S for easy operation
- Large storage of up to 500 weather charts
- Multiple printing options

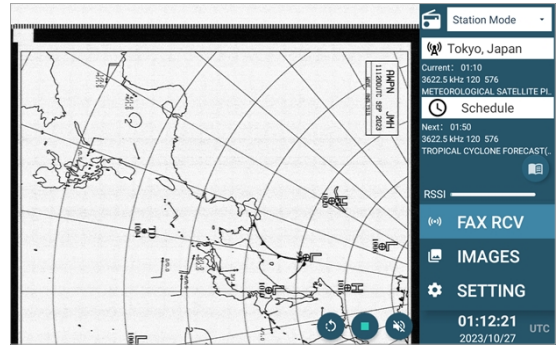

- NFX-3000 is a high-performance marine weather facsimile receiver that receives, displays and stores the weather charts.
- Manual Mode, Station Mode and Schedule Mode for various needs.
- Automatic operation with built-in schedule preset.
- Selected images/charts can be printed in three ways: on a printer directly connected, on a printer connected to the bridge networks and on a printer connected to a PC from USB stick.
- NFX-3000 conforms to the standards of ISO 9876:2015 and IEC 60945.



SPECIFICATIONS

- OS: Android
- LCD Display: Touch screen operation
 - Size: 10.1 inch
 - Resolution: 1280×800
- RAM: 2 GB
- Number of Channels: 1000+
- Frequency Range: 2-25 MHz
- RX Mode: F3C
- Interface: RS422, USB, LAN
- Scanning Speed: 60, 90, 120, 180, 240 r.p.m., manual or automatic selection
- IOC: 576, 288, manual or automatic operation
- Power Supply: DC 24 V (range 9 V ~ 36 V)
- Size: 189.8 (H) × 321.3 (W) × 100.6 (D) mm (Display Unit)
- Weight: 2.2 kg (Display Unit)
- IP Grade: IP22: Display Unit, IP66: Antenna

EQUIPMENT LIST

● STANDARD

- | | | |
|----------------|----------|-------|
| - Display Unit | NFX-3000 | 1 pc |
| - Accessories | | 1 set |

● OPTIONS

- | | | |
|-----------------------|--------|------|
| - AC/DC PSU | PS-10 | 1 pc |
| - Whip Antenna | NHA300 | 1 pc |
| - Flush Mount Bracket | | 1 pc |

SIZE DIMENSION

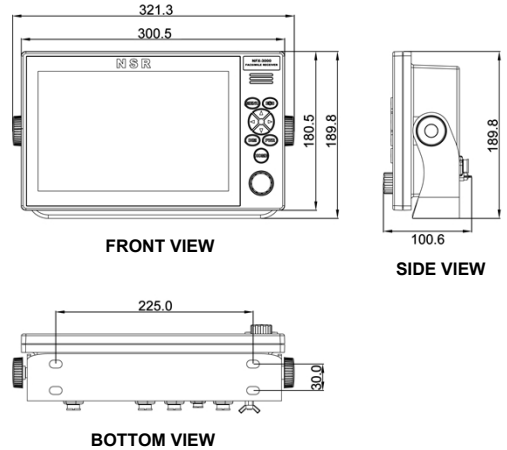

SYSTEM DIAGRAM

